

GATE VALVE



8303 EDGEVALLEY DRIVE NW,
CALGARY, AB, CANADA T3A 4V3

TEL: 1-403-8006686

EMAIL: info@cwtvalve.com

WEBSITE: www.cwtvalve.com



CWT Valve
CWT VALVE INDUSTRIES INC.

TABLE OF CONTENTS

1	CWT FIGURE NUMBER SYSTEM	1~2
2	CAST STEEL BOLTED BONNET GATE VALVE	3~6
3	PRESSURE SEAL BONNET (PSB) GATE VALVE	7~9
4	FORGED STEEL GATE VALVE	10~13
5	SLAB GATE VALVE	14~18
6	PRESSURE-TEMPERATURE RATINGS	19
7	TORQUE VALUE CHART	20
8	INSTALLATION MAINTENANCE AND OPERATING INSTRUCTION	21

CWT FIGURE NUMBER SYSTEM

1. VALVE TYPE	CGA=GATE OS&Y CGS=SLAB GATE		
2. SIZE	25=1/4" 41=1 1/4 50=1/2" 75=3/4" 01=1" 15=1 1/2" 02=2" 21=2 1/2" 03=3"	04=4" 05=5" 06=6" 08=8" 10=10" 12=12" 14=14" 16=16" 18=18"	20=20" 24=24" 26=26" 28=28" 30=30" 32=32" 36=36" 40=40" 42=42"
3. PRESSURE	01=ANSI CLASS 150 03=ANSI CLASS 300 06=ANSI CLASS 600 08=ANSI CLASS 800		09=ANSI CLASS 900 15=ANSI CLASS 1500 25=ANSI CLASS 2500
4. ENDS	RF=RAISED FACE FLANGED JF=RTJ FLANGED RW=RAISED FACE FLANGEDxWELD END JR=RTJxRAISED FACE FLANGED JW=RTJxWELD END SW=SOCKET WELD NI=NPT FEMALE	BW=BUTT WELD FF=FLAT FACE SN=SWxNPT	
5. CONSTRUCTION	B=BOLTED BONNET W=WELDED BONNET S=PRESSURE SEAL BONNET N=SLAB GATE VALVE WITHOUT THROUGH CONDUIT F=SLAB GATE VALVE WITH THROUGH CONDUIT		
6. BODY MATERIAL	01=WCB / A105 02=LCC / LF2 03=CF8M / F316 04=DUPLEX F51 05=DUPLEX F55 06=A105N 07=WCB+ENP / A105+ENP 08=DUCTILE IRON 09=CF8 / F304	10=WC6 / F11 11=C5 / F5 12=CF3 / F304L 13=CF3M / F316L 14=MONEL 15=CN7M (ALLOY 20) 16=C12 / F9 17=WC9 / F22 18=CAST IRON	19=WCC 20=LCB 21=C12A / F91 22=F12 23=F321 24=WC1 25=BRONZE (B61 / B62) 26=F60 27=HASTELLOY

CWT FIGURE NUMBER SYSTEM

7. TRIM MATERIAL	TRIM NUMBER#	WEDGE FACE	SEAT FACE	STEM
	01=13CR	13CR	13CR	13CR
	02=304SS	304SS	304SS	304SS
	05=STL / STL	STL	STL	13CR
	08=13CR / STL	13CR	STL	13CR
	10=316SS	316SS	316SS	316SS
	12=316 / STL	316SS	STL	316SS
	13=ALLOY 20	ALLOY 20	ALLOY 20	ALLOY 20
	14=ALLOY 20 / STL	ALLOY 20	STL	ALLOY 20
	15=STL / STL	STL	STL	304SS
	16=STL / STL	STL	STL	316SS
	19=MONEL	MONEL	MONEL	MONEL
	20=BRONZE	BRONZE	BRONZE	13CR
	23=304SS / STL	304SS	STL	304SS
	27=316L / 316L	316LSS	316LSS	316LSS
	28=316L / STL	316LSS	STL	316LSS
	29=STL / STL	STL	STL	316LSS
	30=F55 / STL	F55	STL	F55

8. OPERATOR		
L=LEVER/WRENCH		E=ELECTRICAL OPERATOR
G=GEAR BOX		P=PNEUMATIC OPERATOR
B=BARE STEM		H=HYDRAULIC OPERATOR
W=HANDWHEEL		S=SOLENOID OPERATOR

9. MATERIAL TYPE		
C=CASTING		F=FORGED

1. PART NUMBER EXAMPLE:

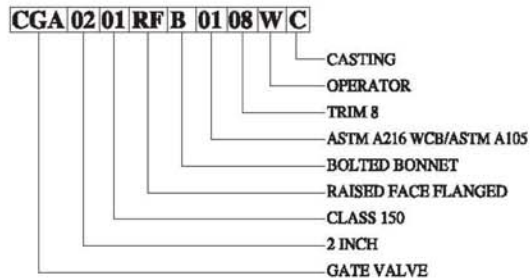

2. SERIES NUMBER EXAMPLE:

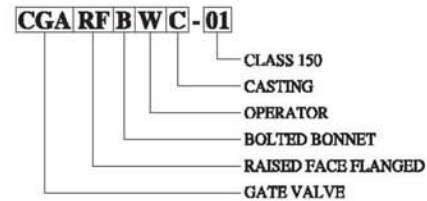

CAST STEEL BOLTED BONNET GATE VALVE

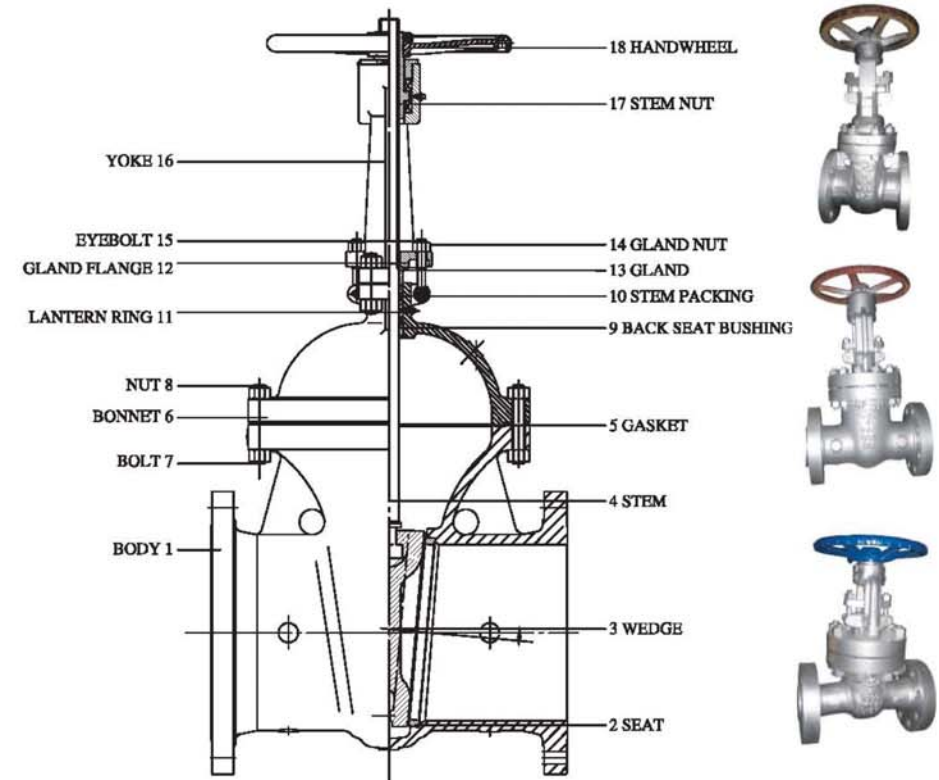

DESIGN FEATURES:

- BOLTED BONNET DESIGN
- WEDGE TYPE: FLEXIBLE WEDGE, SOLID WEDGE, DOUBLE WEDGE
- BODY GASKET: CLASS 150-SMOOTH ELLIPSE COMPOSITE GASKET; CLASS 300-HALF-GROOVE SPIRAL WOUND GASKET; CLASS 600-FULL-GROOVE SPIRAL WOUND GASKET; CLASS 900-1500-OCTAGONAL RING GASKET AND OVAL RING GASKET
- BACK SEAT DESIGN
- STEM IS INTEGRALLY FORGED AND CONNECTED WITH WEDGE BY T-JOINT
- PACKING IS FLEXIBLE GRAPHITE OR OTHER MATERIALS ACCORDING TO CLIENT'S REQUIREMENTS, AND A SPRING-LOADED MECHANISM CAN BE PROVIDED AS PER SPECIAL REQUIREMENTS
- OUTSIDE SCREW AND YOKE (OS&Y)

CAST STEEL BOLTED BONNET GATE VALVE

STANDARDS:

• DESIGN AND MANUFACTURE:	API 600 / ASME B16.34 / BS 1414
• FACE TO FACE DIMENSIONS:	ASME B16.10
• FLANGE ENDS DIMENSIONS:	
NPS 1/2"-24"	ASME B16.5
NPS 26"-36"	ASME B16.47
• BW ENDS DIMENSIONS:	ASME B16.25
• PRESSURE-TEMPERATURE RATINGS:	ASME B16.34
• NORMAL PRESSURE:	CLASS 150-1500
• NORMAL DIAMETER:	NPS 2"-36"

BILL OF MATERIAL (PARTIAL)

ITEM	PART NAME	STANDARD	LOW TEMPERATURE	STAINLESS STEEL
1	BODY	ASTM A216 WCB	ASTM A352 LCC	ASTM A351 CF8M
2	SEAT	ASTM A105	ASTM A350 LF2	ASTM A182 F316
3	WEDGE	ASTM A216 WCB	ASTM A352 LCC	ASTM A351 CF8M
4	STEM	ASTM A182 F6	ASTM A182 F304	ASTM A182 F316
5	GASKET	304SS/316SS+GRAPHITE / SOFT STEEL / 304SS/316SS METAL RING		
6	BONNET	ASTM A216 WCB	ASTM A352 LCC	ASTM A351 CF8M
7	BOLT	ASTM A193 B7/B7M	ASTM A320 L7/L7M	ASTM A193 B8M
8	NUT	ASTM A194 2H/2HM	ASTM A194 7/7M	ASTM A194 8M
9	BACK SEAT BUSHING	ASTM 276 410	ASTM A276 304	ASTM A276 316
10	PACKING	GRAPHITE / PTFE		
11★	LANTERN RING	ASTM 276 410	ASTM 276 304	ASTM A276 316
12	GLAND FLANGE	ASTM A216 WCB	ASTM A352 LCC	ASTM A351 CF8
13	GLAND	ASTM 276 410	ASTM 276 410	ASTM A276 316
14	GLAND NUT	ASTM A194 2H/2HM	ASTM A194 7/7M	ASTM A194 8
15	EYEBOLT	ASTM A193 B7/B7M	ASTM A320 L7/L7M	ASTM A193 B8
16	STEM NUT	ASTM A439 D2/Cu-ALLOY		
17	YOKE	ASTM A216 WCB	ASTM A352 LCC	ASTM A351 CF8
18◆	HANDWHEEL	STEEL / DUCTILE IRON		
	SEALING FACE OVERLAY	API TRIMS AVAILABLE		

★ AVAILABLE UPON REQUEST FOR CLASS 300 AND ABOVE

◆ GEAR OPERATOR, ELECTRICAL OPERATOR, PNEUMATIC OPERATOR, HYDRAULIC OPERATOR AND ETC. ARE AVAILABLE

NOTE: OTHER MATERIALS ARE AVAILABLE UPON REQUEST

CAST STEEL BOLTED BONNET GATE VALVE

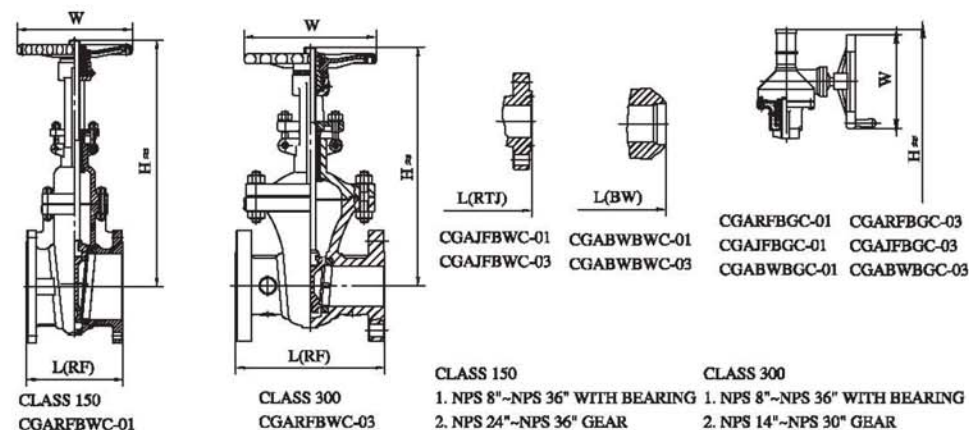

CLASS 150

NPS	in	2	2-1/2	3	4	5	6	8	10	12	14	16	18	20	24	26	28	30	32	36
DN	mm	50	65	80	100	125	150	200	250	300	350	400	450	500	600	650	700	750	800	900
L(RF)	mm	178	191	203	229	254	267	292	330	356	381	406	432	457	508	559	610	610	660	711
L(BW)	mm	216	241	283	305	381	403	419	457	502	572	610	660	711	813	864	914	914	965	1016
L(RTJ)	mm	191	203	216	241	267	279	305	343	368	394	419	445	470	521	570	622	622	673	724
H(OPEN)	mm	395	435	485	592	675	765	960	1160	1352	1510	1703	1895	2120	2530	2920	3050	3150	3285	3825
W	mm	200	200	250	250	300	300	350	400	450	500	550	600	680	610	610	610	610	610	610
WT(RF)	Kg	20	28	36	52	72	85	127	195	283	398	524	690	900	1135	1500	1935	2800	3200	3820
WT(BW)	Kg	15	22	26	40	68	77	118	185	270	370	500	650	880	1100	1480	1800	2610	3000	3600

CLASS 300

NPS	in	2	2-1/2	3	4	5	6	8	10	12	14	16	18	20	24	30
DN	mm	50	65	80	100	125	150	200	250	300	350	400	450	500	600	750
L(RF)	mm	216	241	283	305	381	403	419	457	502	762	838	914	991	1143	1397
L(BW)	mm	216	241	283	305	381	403	419	457	502	762	838	914	991	1143	1397
L(RTJ)	mm	232	257	298	321	397	419	435	473	518	778	854	930	1010	1165	1422
H(OPEN)	mm	410	453	515	615	712	810	1012	1212	1415	1650	1840	2030	2240	2900	3540
W	mm	200	200	250	250	300	350	400	450	500	460	460	610	610	610	610
WT(RF)	Kg	27	44	50	74	124	137	217	337	580	715	1050	1235	1655	2320	3820
WT(BW)	Kg	20	35	37	54	100	110	174	285	495	615	840	1090	1500	2100	3500

CAST STEEL BOLTED BONNET GATE VALVE

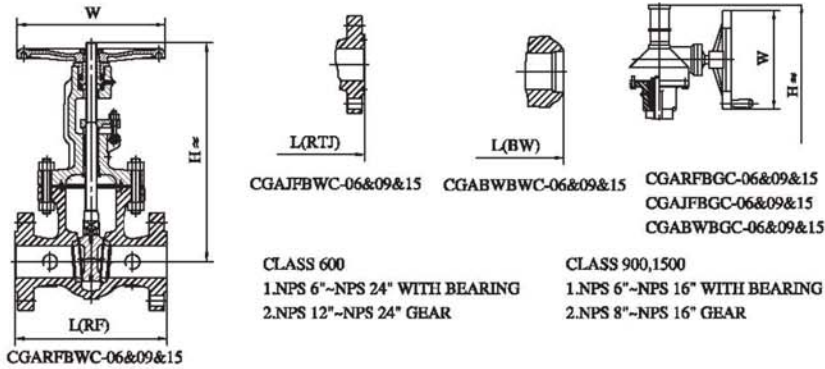

CLASS 600

NPS	in	2	2-1/2	3	4	5	6	8	10	12	14	16	18	20	24
DN	mm	50	65	80	100	125	150	200	250	300	350	400	450	500	600
L(RF)	mm	292	330	356	432	508	559	660	787	838	889	991	1092	1194	1397
L(BW)	mm	292	330	356	432	508	559	660	787	838	889	991	1092	1194	1397
L(RTJ)	mm	295	333	359	435	511	562	663	790	841	892	994	1095	1200	1407
H(OPEN)	mm	418	476	518	646	770	839	1024	1229	1450	1730	1835	2290	2510	3022
W	mm	250	250	300	350	400	500	600	720	610	610	610	610	760	760
WT(RF)	Kg	40	55	70	123	148	245	426	700	940	1310	1610	2070	2405	4560
WT(BW)	Kg	32	47	64	103	125	218	374	570	830	1012	1217	1760	2000	4228

CLASS 900

NPS	in	2	2-1/2	3	4	6	8	10	12	14	16
DN	mm	50	65	80	100	150	200	250	300	350	400
L(RF)	mm	368	419	381	457	610	737	838	965	1029	1130
L(BW)	mm	368	419	381	457	610	737	838	965	1029	1130
L(RTJ)	mm	371	422	384	460	613	740	841	968	1038	1140
H(OPEN)	mm	547	580	600	679	900	1103	1590	1795	2025	2170
W	mm	300	350	400	450	550	460	610	610	760	760
WT(RF)	Kg	95	128	155	192	378	635	900	1550	2170	3070
WT(BW)	Kg	80	110	125	165	330	520	730	1300	1800	2650

CLASS 1500

NPS	in	2	2-1/2	3	4	6	8	10	12	14	16
DN	mm	50	65	80	100	150	200	250	300	350	400
L(RF)	mm	368	419	470	546	705	832	991	1130	1257	1384
L(BW)	mm	368	419	470	546	705	832	991	1130	1257	1384
L(RTJ)	mm	371	422	473	549	711	841	1000	1146	1276	1407
H(OPEN)	mm	547	580	806	887	1079	1370	1520	1651	1945	2250
W	mm	350	400	450	550	460	610	760	760	760	760
WT(RF)	Kg	95	128	181	275	627	1000	2200	2850	3320	-
WT(BW)	Kg	80	110	145	220	560	850	1950	2580	3020	-

PRESSURE SEAL BONNET (PSB) GATE VALVE

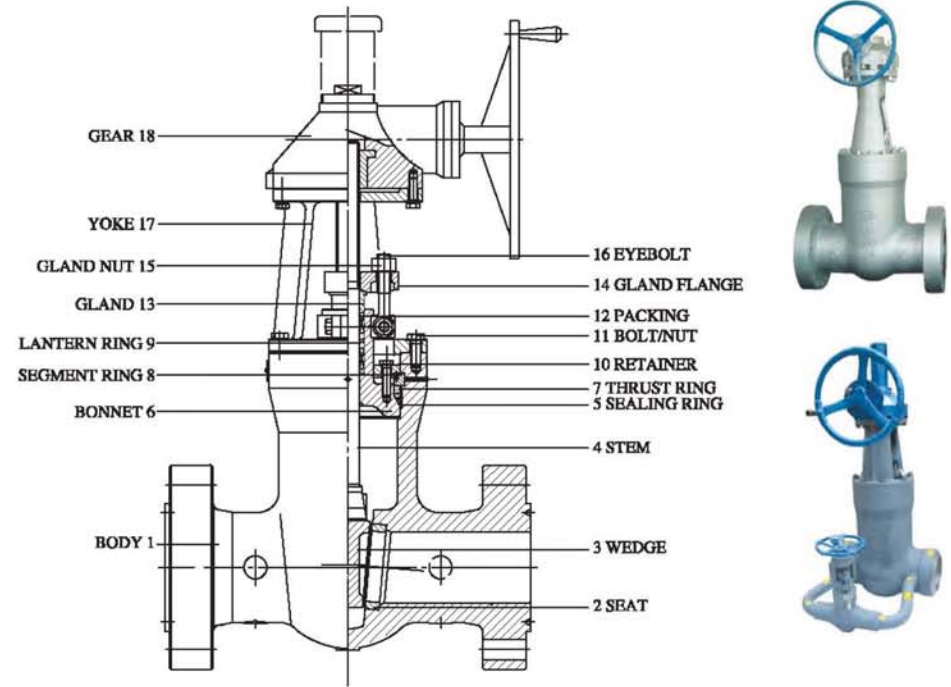

DESIGN FEATURES:

- PRESSURE SEAL BONNET (PSB) DESIGN
- WEDGE TYPE: FLEXIBLE WEDGE, SOLID WEDGE, DOUBLE WEDGE
- BACK SEAT DESIGN
- STEM IS INTEGRALLY FORGED AND CONNECTED WITH WEDGE BY T-JOINT
- PACKING IS FLEXIBLE GRAPHITE OR OTHER MATERIALS ACCORDING TO CLIENT'S REQUIREMENTS, AND A SPRING-LOADED MECHANISM CAN BE PROVIDED AS PER SPECIAL REQUIREMENTS
- OUTSIDE SCREW AND YOKE (OS&Y)

PRESSURE SEAL BONNET (PSB) GATE VALVE

STANDARDS:

• DESIGN AND MANUFACTURE:	API 600
• FACE TO FACE DIMENSIONS:	ASME B16.10
• FLANGE ENDS DIMENSIONS:	
NPS 1/2"–24"	ASME B16.5
NPS 26"–36"	ASME B16.47
• BW ENDS DIMENSIONS:	ASME B16.25
• PRESSURE-TEMPERATURE RATINGS:	ASME B16.34
• NORMAL PRESSURE:	CLASS 900–2500
• NORMAL DIAMETER:	NPS 2"–16"

BILL OF MATERIAL (PARTIAL)

ITEM	PART NAME	STANDARD	ALLOY CARBON STEEL	STAINLESS STEEL
1	BODY	ASTM A216 WCB	ASTM A217 WC6	ASTM A351 CF8M
2	SEAT	ASTM A105	ASTM A182 F11	ASTM A182 F316
3	WEDGE	ASTM A216 WCB	ASTM A217 WC6	ASTM A351 CF8M
4	STEM	ASTM A182 F6	AISI 4140/4340	ASTM A182 F316
5	SEALING RING	AISI 1008 / SS304L / SS316L		
6	BONNET	ASTM A216 WCB	ASTM A217 WC6	ASTM A351 CF8M
7	THRUST RING	ASTM A276 410	ASTM A276 410	ASTM A276 316
8	SEGMENT RING	ASTM A276 410	ASTM A276 410	ASTM A276 316
9*	LANTERN RING	ASTM 276 410	ASTM 276 410	ASTM A276 316
10	RETAINER	AISI 1025	ASTM 182 F11	ASTM 182 F316
11	BOLT/NUT	ASTM A193 B7/B7M/ASTM A194 2H/2HM	ASTM A193 B16/A194 4	ASTM A193 B8M/A194 8M
12	PACKING	GRAPHITE / PTFE		
13	GLAND	ASTM 276 410	ASTM 276 410	ASTM A276 316
14	GLAND FLANGE	ASTM A216 WCB	ASTM A217 WC6	ASTM A351 CF8
15	GLAND NUT	ASTM A194 2H/2HM	ASTM A194 4	ASTM A194 8
16	EYEBOLT	ASTM A193 B7/B7M	ASTM A193 B16	ASTM A193 B8
17	YOKE	ASTM A216 WCB	ASTM A217 WC6	ASTM A351 CF8
18♦	GEAR	ASSEMBLY		
	SEALING FACE OVERLAY	API TRIMS AVAILABLE		

* AVAILABLE UPON REQUEST FOR CLASS 300 AND ABOVE

♦ GEAR OPERATOR, ELECTRICAL OPERATOR, PNEUMATIC OPERATOR, HYDRAULIC OPERATOR AND ETC. ARE AVAILABLE

NOTE: OTHER MATERIALS ARE AVAILABLE UPON REQUEST

PRESSURE SEAL BONNET (PSB) GATE VALVE

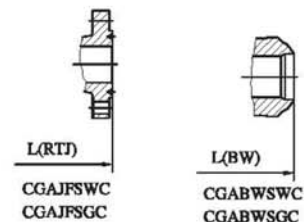
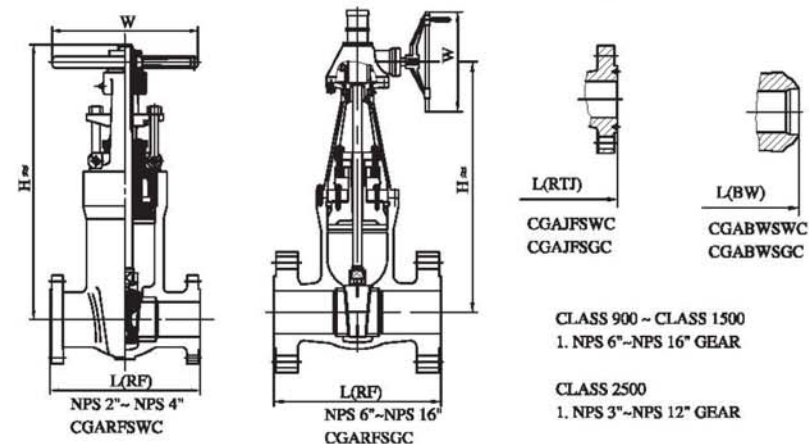

CLASS 900 – CLASS 1500
1. NPS 6"–NPS 16" GEAR

CLASS 2500
1. NPS 3"–NPS 12" GEAR

CLASS 900

NPS	in	2	2-1/2	3	4	6	8	10	12	14	16
DN	mm	50	65	80	100	150	200	250	300	350	400
L(RF)	mm	368	419	381	457	610	737	838	965	1029	1130
L(BW)	mm	216	254	305	356	508	660	787	914	991	1092
L(RTJ)	mm	371	422	384	460	613	740	841	968	1038	1140
H(OPEN)	mm	600	653	684	843	1092	1372	1494	1892	2144	2046
W	mm	300	350	400	450	550	460	610	610	760	760
WT(BW)	Kg	42	45	60	120	280	465	690	942	1440	1990

CLASS 1500

NPS	in	2	2-1/2	3	4	6	8	10	12	14	16
DN	mm	50	65	80	100	150	200	250	300	350	400
L(RF)	mm	368	419	470	546	705	832	991	1130	1257	1384
L(BW)	mm	216	254	305	406	559	711	864	991	1067	1194
L(RTJ)	mm	371	422	473	549	711	841	1000	1146	1276	1407
H(OPEN)	mm	600	653	700	850	1168	1372	1655	1810	2215	2330
W	mm	350	400	450	550	460	610	760	760	760	760
WT(BW)	Kg	42	45	60	125	400	586	974	1464	2140	2750

CLASS 2500

NPS	in	2	2-1/2	3	4	6	8	10	12
DN	mm	50	65	80	100	150	200	250	300
L(RF)	mm	451	508	578	673	914	1022	1270	1422
L(BW)	mm	279	330	368	457	610	762	914	1041
L(RTJ)	mm	454	514	584	683	927	1038	1292	1445
H(OPEN)	mm	620	647	760	982	933	1345	1685	1750
W	mm	350	400	450	550	610	610	760	800
WT(BW)	Kg	52	55	80	130	480	828	1230	1943

FORGED STEEL GATE VALVE

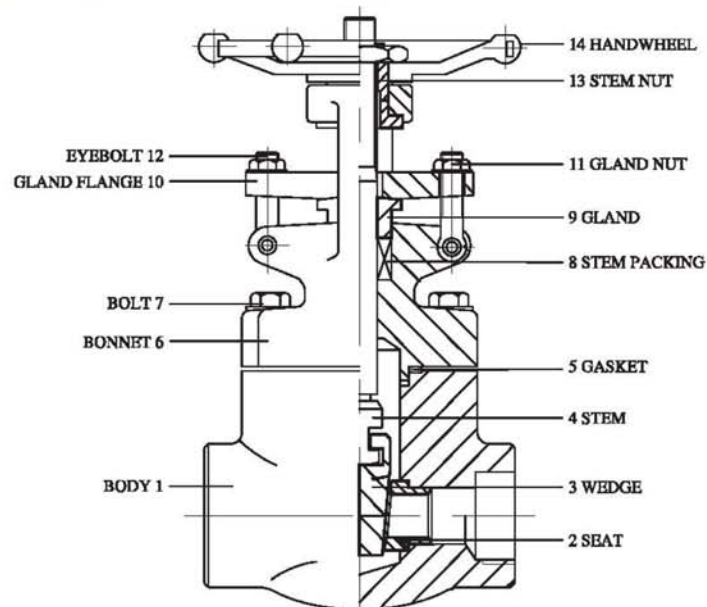

DESIGN FEATURES:

- BOLTED BONNET OR WELDED BONNET
- WEDGE TYPE: SOLID WEDGE
- BACK SEAT DESIGN
- STEM IS INTEGRALLY FORGED AND CONNECTED WITH WEDGE BY T-JOINT
- PACKING IS FLEXIBLE GRAPHITE OR OTHER MATERIALS ACCORDING TO CLIENT'S REQUIREMENTS, AND A SPRING-LOADED MECHANISM CAN BE PROVIDED AS PER SPECIAL REQUIREMENTS
- OUTSIDE SCREW AND YOKE (OS&Y)

FORGED STEEL GATE VALVE

STANDARDS:

- DESIGN AND MANUFACTURE: API 602 (BS 5352)
- FACE TO FACE DIMENSIONS: ASME B16.10 OR MANUFACTURER'S SPECIFICATION
- FLANGE ENDS DIMENSIONS: ASME B16.5
- BW ENDS DIMENSIONS: ASME B16.25
- SOCKET WELD ENDS DIMENSIONS: ASME B16.11
- THREADED ENDS DIMENSIONS: ASME B1.20.1
- PRESSURE-TEMPERATURE RATINGS: ASME B16.34
- NORMAL PRESSURE: CLASS 150-1500
- NORMAL DIAMETER: NPS 1/2"-2"

BILL OF MATERIAL (PARTIAL)

ITEM	PART NAME	STANDARD	LOW TEMPERATURE	STAINLESS STEEL
1	BODY	ASTM A105	ASTM A350 LF2	ASTM A182 F316
2	SEAT	ASTM A105	ASTM A350 LF2	ASTM A182 F316
3	WEDGE	ASTM A105	ASTM A350 LF2	ASTM A182 F316
4	STEM	ASTM A182 F6	ASTM A182 F304	ASTM A182 F316
5	GASKET	304SS/316SS+GRAPHITE / SOFT CARBON STEEL / 304SS/316SS METAL RING		
6	BONNET	ASTM A105	ASTM A350 LF2	ASTM A182 F316
7	BOLT	ASTM A193 B7/B7M	ASTM A320 L7/L7M	ASTM A193 B8M
8	STEM PACKING	GRAPHITE / PTFE		
9	GLAND	ASTM 276 410	ASTM 276 410	ASTM A276 316
10	GLAND FLANGE	ASTM A105	ASTM A350 LF2	ASTM A182 F316
11	GLAND NUT	ASTM A194 2H/2HM	ASTM A194 7/7M	ASTM A194 8
12	EYEBOLT	ASTM A193 B7/B7M	ASTM A320 L7/L7M	ASTM A193 B8
13	STEM NUT	ASTM A276 420 / Cu-ALLOY		
14◆	HANDWHEEL	STEEL / DUCTILE IRON		
	SEALING FACE OVERLAY	API TRIMS AVAILABLE		

◆ ELECTRICAL OPERATOR AND PNEUMATIC OPERATOR ARE AVAILABLE

NOTE: OTHER MATERIALS ARE AVAILABLE UPON REQUEST

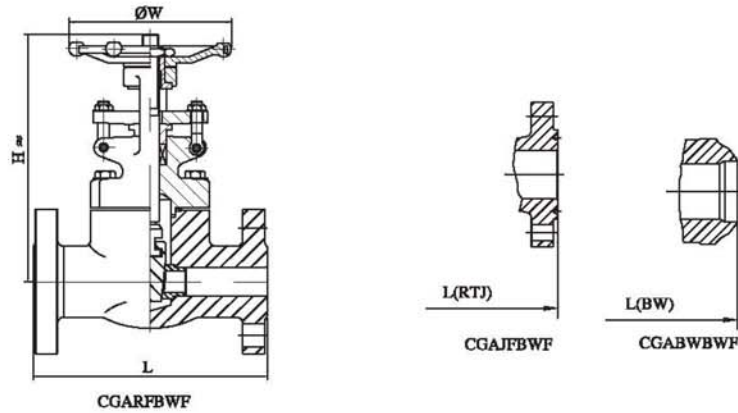
FORGED STEEL GATE VALVE

CLASS 150

NPS	in	1/2	3/4	1	1-1/4	1-1/2	2
DN	mm	15	20	25	32	40	50
L(RF)	mm	108	117	127	140	165	178
L(BW)	mm	108	117	127	140	165	178
L(RT)	mm	-	-	140	152	178	191
H(OPEN)	mm	168	173	210	223	253	292
W	mm	100	100	120	160	160	180
WT(RF)	Kg	4.0	5.2	6.6	8.2	11.5	16.3
WT(BW)	Kg	3.0	3.6	5.8	6.8	9	13.5

CLASS 300

NPS	in	1/2	3/4	1	1-1/4	1-1/2	2
DN	mm	15	20	25	32	40	50
L(RF)	mm	140	152	165	178	191	216
L(BW)	mm	140	152	165	178	191	216
L(RT)	mm	151	165	178	191	203	232
H(OPEN)	mm	168	173	210	223	253	292
W	mm	100	100	120	160	160	180
WT(RF)	Kg	4.6	6.5	7.2	9.8	14	19.3
WT(BW)	Kg	3.8	4.5	6.1	8.0	10.5	15.5

CLASS 600

NPS	in	1/2	3/4	1	1-1/4	1-1/2	2
DN	mm	15	20	25	32	40	50
L(RF)	mm	165	191	216	229	241	292
L(BW)	mm	165	191	216	229	241	292
L(RT)	mm	163.5	191	216	229	241	295
H(OPEN)	mm	168	173	210	223	253	292
W	mm	100	100	120	160	160	180
WT(RF)	Kg	5.2	7.3	10	12	16	21
WT(BW)	Kg	4.8	6.5	8.5	10.2	12.5	20.4

CLASS 900-CLASS 1500

NPS	in	1/2	3/4	1	1-1/4	1-1/2	2
DN	mm	15	20	25	32	40	50
L(RF)	mm	216	229	254	279	305	368
L(BW)	mm	216	229	254	279	305	368
L(RT)	mm	216	229	254	279	305	368
H(OPEN)	mm	198	212	240	265	280	322
W	mm	125	125	160	220	220	250
WT(RF)	Kg	7.5	11.5	15.5	19	22.9	28.5
WT(BW)	Kg	7.0	10.5	14.6	18.5	22.2	27.5

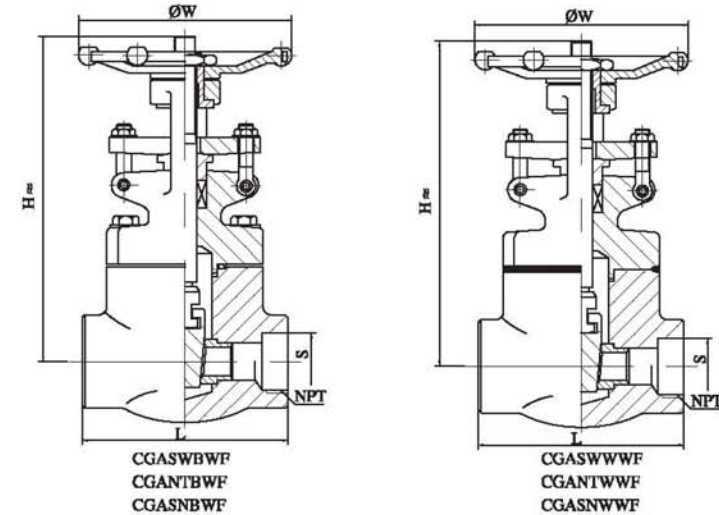
FORGED STEEL GATE VALVE

CLASS 150-CLASS 800

NPS	in	1/2	3/4	1	1-1/4	1-1/2	2
DN	mm	15	20	25	32	40	50
L	mm	79	92	111	120	120	140
S	mm	21.8	27.1	33.8	42.6	48.7	61.1
NPT	in	1/2	3/4	1	1-1/4	1-1/2	2
H(OPEN)	mm	168	173	210	223	253	292
W	mm	100	100	120	160	160	180
WT	Kg	2.1	2.3	4.3	5.8	6.9	10.8

CLASS 900-CLASS 1500

NPS	in	1/2	3/4	1	1-1/4	1-1/2	2
DN	mm	15	20	25	32	40	50
L	mm	102	111	120	140	140	178
S	mm	21.8	27.1	33.8	42.6	48.7	61.1
NPT	in	1/2	3/4	1	1-1/4	1-1/2	2
H(OPEN)	mm	198	212	240	265	280	322
W	mm	125	125	160	220	220	250
WT	Kg	3.5	4.0	7.5	10.5	12.1	20

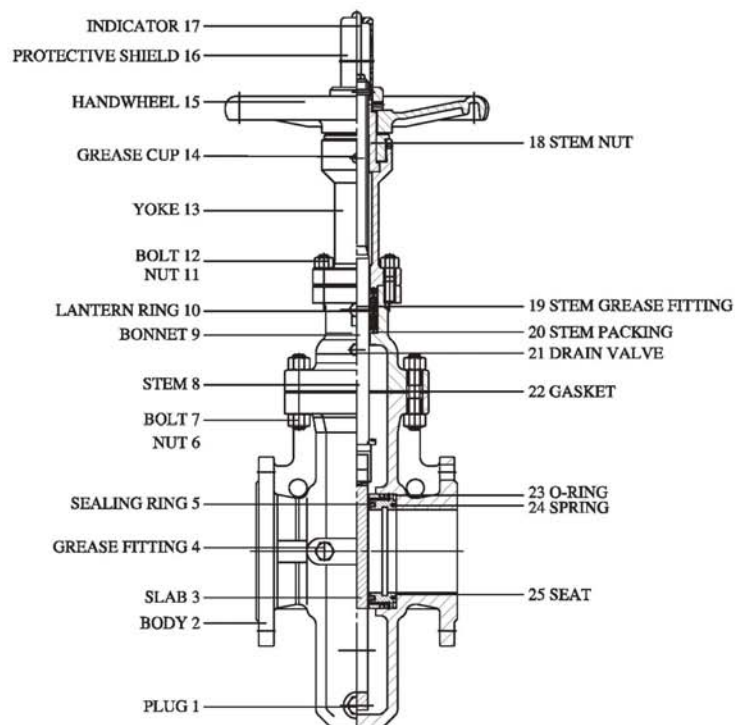
SLAB GATE VALVE



DESIGN FEATURES:

- WEDGE TYPE: SINGLE WEDGE, SINGLE WEDGE WITH THROUGH CONDUIT, DOUBLE WEDGE WITH THROUGH CONDUIT
- DOUBLE SEALING SEATS. IT CAN BE URGENTLY SEATED BY INJECTING GREASE THROUGH A GREASE INJECTION VALVE
- DOUBLE BLOCK AND BLEED (DDB) DESIGN
- PACKING IS FLEXIBLE GRAPHITE OR ACCORDING TO CLIENTS' REQUIREMENTS.
- OUTSIDE SCREW AND YOKE (OS&Y)
- WITH PROTECTIVE SHIELD AND INDICATOR

SLAB GATE VALVE

STANDARDS:

- DESIGN AND MANUFACTURE: API 6D
- FACE TO FACE DIMENSIONS: API 6D
- FLANGE ENDS DIMENSIONS:
 - NPS 2"-24" ASME B16.5
 - NPS 26"-36" ASME B16.47
- BW ENDS DIMENSIONS: ASME B16.25
- PRESSURE-TEMPERATURE RATINGS: ASME B16.34
- NORMAL PRESSURE: CLASS 150-1500
- NORMAL DIAMETER: NPS 2"-36"

BILL OF MATERIAL (PARTIAL)

ITEM	PART NAME	STANDARD	LOW TEMPERATURE	STAINLESS STEEL
1	PLUG	CARBON STEEL	STAINLESS STEEL	SS316
2	BODY	ASTM A216 WCB	ASTM A352 LCB	ASTM A351 CF8M
3	SLAB	ASTM A276 410	ASTM A276 304	ASTM A276 316
4	GREASE FITTING	CARBON STEEL	STAINLESS STEEL	SS316
5	SEALING RING	PTFE / RPTFE / NYLON	PTFE / RPTFE / NYLON	PTFE / RPTFE / NYLON
6	NUT	ASTM A194 2H/2HM	ASTM A194 7/7M	ASTM A194 8
7	BOLT	ASTM A193 B7/B7M	ASTM A320 L7/L7M	ASTM A193 B8
8	STEM	ASTM A182 F6	ASTM A182 F304	ASTM A182 F316
9	BONNET	ASTM A216 WCB	ASTM A352 LCB	ASTM A351 CF8M
10	LANTERN RING	ASTM 276 410	ASTM 276 304	ASTM A276 316
11	NUT	ASTM A194 2H/2HM	ASTM A194 7/7M	ASTM A194 8
12	BOLT	ASTM A193 B7/B7M	ASTM A320 L7/L7M	ASTM A193 B8
13	YOKE	ASTM A216 WCB	ASTM A352 LCB	ASTM A351 CF8
14	CREASE CUP	CARBON STEEL	CARBON STEEL	STAINLESS STEEL
15♦	HANDWHEEL	STEEL / DUCTILE IRON		
16	PROTECTIVE SHIELD	CARBON STEEL		
17	INDICATOR	STAINLESS STEEL		
18	STEM NUT	ASTM A439 D2 / Cu-ALLOY		
19	STEM GREASE FITTING	CARBON STEEL	STAINLESS	SS316
20	STEM PACKING	GRAPHITE/PTFE		
21	DRAIN VALVE	CARBON STEEL	STAINLESS STEEL	SS316
22	GASKET	304SS/316SS+GRAPHITE / SOFT STEEL / 304SS/316SS METAL RING		
23	O-RING	VITON		
24	SPRING	INCONEL X750		
25	SEAT	ASTM A105+ENP	ASTM 350 LF2+ENP	ASTM A182 F316
API TRIMS AVAILABLE				

♦ GEAR OPERATOR, ELECTRICAL OPERATOR, PNEUMATIC OPERATOR, HYDRAULIC OPERATOR ADN ETC. ARE AVAILABLE
 NOTE: OTHER MATERIALS ARE AVAILABLE UPON REQUEST

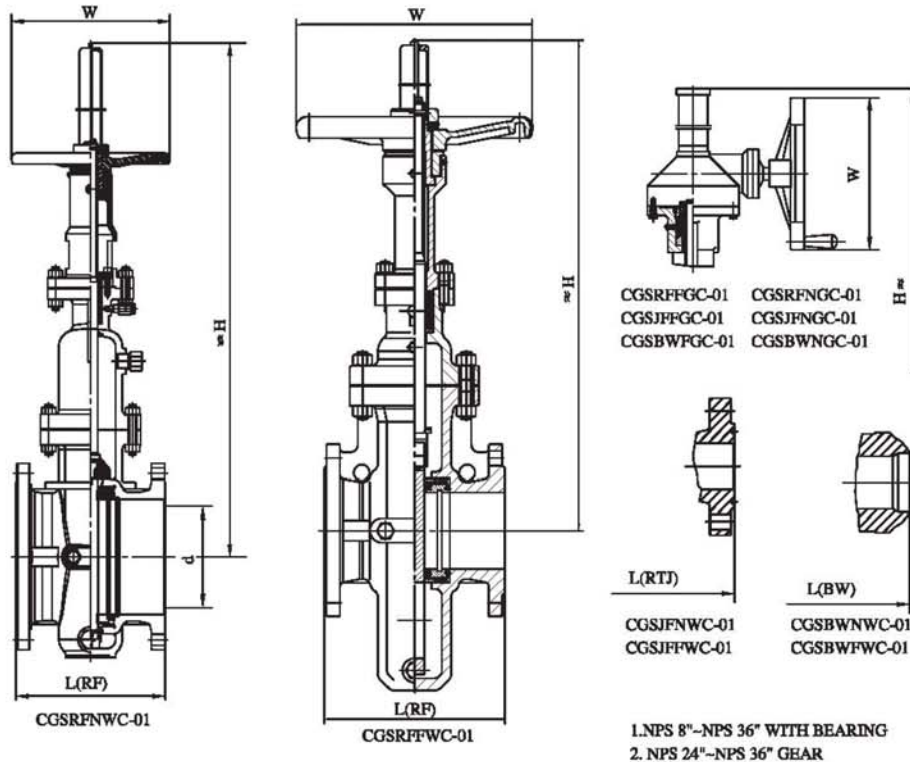
SLAB GATE VALVE

CLASS 150

NPS	in	2	2-1/2	3	4	5	6	8	10	12	14	16	18	20	24	26	28	30	32	36
DN	mm	50	65	80	100	125	150	200	250	300	350	400	450	500	600	650	700	750	800	900
L(RF)	mm	178	191	203	229	254	267	292	330	356	381	406	432	457	508	559	610	610	711	711
L(BW)	mm	216	241	283	305	381	403	419	457	502	572	610	660	711	813	864	914	914	965	1016
L(RTJ)	mm	191	203	216	241	267	279	305	343	368	394	419	445	470	521	570	622	622	673	724
H(OPEN)	mm	395	505	556	667	745	866	1064	1235	1420	1600	1800	2110	2200	2850	3050	3300	3500	3720	4150
W	mm	200	200	250	250	300	300	350	400	450	500	550	600	680	610	610	610	610	610	610
WT(RF)	Kg	52	65	69	98	128	178	292	335	480	735	992	1275	1630	2632	6064	3645	4285	5160	7066

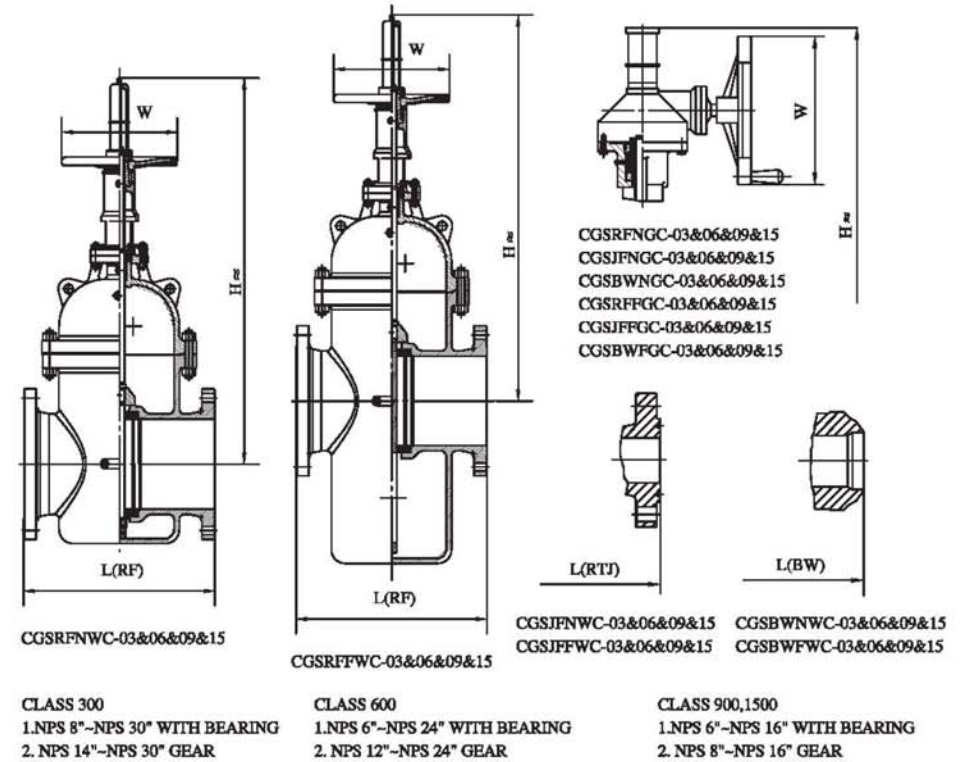
THE WEIGHT IS FOR THROUGH CONDUIT SLAB GATE VALVE

SLAB GATE VALVE

CLASS 300

NPS	in	2	2-1/2	3	4	5	6	8	10	12	14	16	18	20	24	30
DN	mm	50	65	80	100	125	150	200	250	300	350	400	450	500	600	750
L(RF)	mm	216	241	283	305	381	403	419	457	502	762	838	914	991	1143	1397
L(BW)	mm	216	241	283	305	381	403	419	457	502	762	838	914	991	1143	1397
L(RTJ)	mm	232	257	298	321	397	419	435	473	518	778	854	930	1010	1165	1422
H(OPEN)	mm	410	553	615	710	780	900	1112	1312	1515	1720	1912	2130	2420	2900	3540
W	mm	200	200	250	250	300	350	400	450	500	460	460	610	610	610	610
WT(RF)	Kg	58	61	79	155	178	195	333	496	693	1002	1410	1911	2412	3750	6190

THE WEIGHT IS FOR THROUGH CONDUIT SLAB GATE VALVE

SLAB GATE VALVE

CLASS 600

NPS	in	2	2-1/2	3	4	5	6	8	10	12	14	16	18	20	24
DN	mm	50	65	80	100	125	150	200	250	300	350	400	450	500	600
L(RF)	mm	292	330	356	432	508	559	660	787	838	889	991	1092	1194	1397
L(BW)	mm	292	330	356	432	508	559	660	787	838	889	991	1092	1194	1397
L(RTJ)	mm	295	333	359	435	511	562	664	791	841	892	994	1095	1200	1407
H(OPEN)	mm	448	560	612	726	850	920	1156	1398	1588	1730	1835	2290	2510	3022
W	mm	250	250	300	350	400	500	600	720	610	610	610	610	760	760
WT(RF)	Kg	80	105	111	155	184	308	486	756	1356	1683	2016	2681	2988	4845

CLASS 900

NPS	in	2	2-1/2	3	4	6	8	10	12	14	16
DN	mm	50	65	80	100	150	200	250	300	350	400
L(RF)	mm	368	419	381	457	610	737	838	965	1029	1130
L(BW)	mm	368	419	381	457	610	737	838	965	1029	1130
L(RTJ)	mm	371	422	384	460	613	740	841	968	1038	1140
H(OPEN)	mm	650	765	795	860	1080	1625	1920	2156	2442	2650
W	mm	300	350	400	450	550	460	610	610	760	760
WT(RF)	Kg	100	146	188	245	445	710	1035	1722	2476	2750

CLASS 1500

NPS	in	2	2-1/2	3	4	6	8	10	12	14	16
DN	mm	50	65	80	100	150	200	250	300	350	400
L(RF)	mm	368	419	470	546	705	832	991	1130	1257	1384
L(BW)	mm	368	419	470	546	705	832	991	1130	1257	1384
L(RTJ)	mm	371	422	473	549	711	841	1000	1146	1276	1407
H(OPEN)	mm	725	765	806	960	1188	1710	2080	2415	2688	2940
W	mm	350	400	450	550	460	610	760	760	760	760
WT(RF)	Kg	175	280	380	443	842	1340	1965	3260	4695	5215

THE WEIGHT IS FOR THROUGH CONDUIT SLAB GATE VALVE

PRESSURE-TEMPERATURE RATINGS TO ASME B16.34

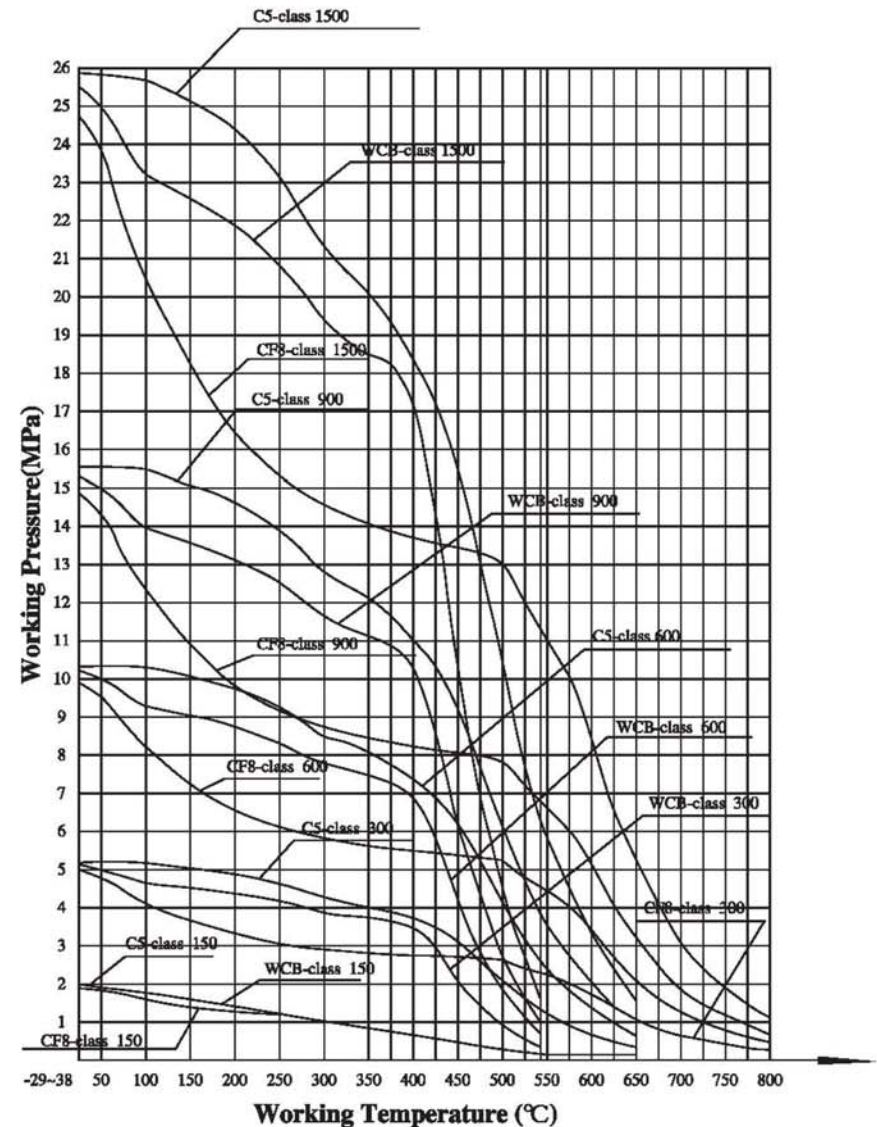

TORQUE VALUE CHART

GATE VALVE CLASS 150

SIZE	STEM DIAMETER	ACME	TORQUE N.M	LH OR RH	TURN NUMBER	TOLERANCE GRADE
3"	0.875"	5ACME	72	LH	18	2G
4"	1"	5ACME	120	LH	23	2G
6"	1.125"	4ACME	230	LH	26	2G
8"	1.25"	4ACME	300	LH	35	2G
10"	1.375"	4ACME	300	LH	43	2G
12"	1.5"	4ACME	450	LH	52	2G
14"	1.625"	3ACME	600	LH	43	2G
16"	1.75"	3ACME	900	LH	49	2G
18"	1.875"	3ACME	1200	LH	56	2G
20"	2"	3ACME	1800	LH	61	2G
24"	2.25"	3ACME	2400	LH	77	2G
36"	3"	2ACME	6000	LH	69	2G

GATE VALVE CLASS 300

SIZE	STEM DIAMETER	ACME	TORQUE N.M	LH OR RH	TURN NUMBER	TOLERANCE GRADE
3"	0.875"	5ACME	140	LH	18	2G
4"	1"	5ACME	220	LH	24	2G
6"	1.25"	4ACME	430	LH	27	2G
8"	1.375"	4ACME	450	LH	35	2G
10"	1.5"	4ACME	520	LH	44	2G
12"	1.625"	3ACME	900	LH	39	2G
14"	1.75"	3ACME	1200	LH	43	2G
16"	1.875"	3ACME	1800	LH	49	2G

GATE VALVE CLASS 600

SIZE	STEM DIAMETER	ACME	TORQUE N.M	LH OR RH	TURN NUMBER	TOLERANCE GRADE
3"	1"	5ACME	400	LH	18	2G
4"	1.125"	4ACME	500	LH	19	2G
6"	1.5"	4ACME	500	LH	27	2G
8"	1.625"	3ACME	750	LH	27	2G
10"	1.875"	3ACME	1200	LH	33	2G

INSTALLATION, MAINTENANCE AND OPERATING INSTRUCTION GATE AND GLOBE VALVES

1.0 WARNING

For your safety and protection, it is important that the following precautions be taken prior to removing the valve from service, or before any disassembly of the valve:

- 1.1 Keep hands safely out of the valve at all times during this entire procedure to avoid accidents that may cause serious injury. (i.e.: closure of valve by a remote controlled actuator.)
- 1.2 Know what media is in the line. If there is any doubt, check with the proper authority.
- 1.3 Wear any protective clothing or equipment normally required when working with the media involved.
- 1.4 Body ratings-the practical and safe use of this product is determined by body ratings. Read the name tag and check ratings. Do not exceed these ratings.

2.0 INSTALLATION

- 2.1 Place the valve in the open position.
- 2.2 Flow through the valve can be in either direction. For good performance however, it is recommended that the valve be installed conforming to the actual pipeline conditions.
- 2.3 The valve should be tightened between flanges using appropriate gaskets and fasteners for the service. Tighten the bolts in compliance with the requirements of the gasket manufacturer.
- 2.4 If there is seepage past the packing upon installation, the valve may have been subjected to wide temperature variations in shipment. "Leak-tight" performance will be restored by a packing adjustment described in the maintenance section.
- 2.5 Before installation, carefully check the valve markings and pressure rating to ensure the valve is suitable for service.

3.0 OPERATING

- 3.1 Turn handle clockwise to close and anti-clockwise to open.
- 3.2 The rising stem indicates valve open or closed position.
- 3.3 Valve should be totally open or closed in the usage process and not suggested to use as a throttling valve.

4.0 MAINTENANCE

- 4.1 General Maintenance requires periodic observation to ensure that the valve is functioning well. Routine maintenance consists of tightening the packing periodically to compensate for stem seal wear.
- 4.2 Overhaul Maintenance consists of replacing seats and seals. A standard service kit consisting of these parts may be obtained through your local CanaWest distributor.

5.0 TROUBLE SHOOTING

PROBLEM	CAUSE	CLEAN UP METHOD
Valve operation is difficult.	1. There is foreign matter of damage between the stem and stem nut's thread.	Disassemble the stem nut to clean or replace.
	2. Leakage of lubrication.	Inject lubricant.
	3. Bent stem.	Alignment or change the stem.
	4. The packing is too tight.	Re-adjust the packing tightness or symmetry.
Leakage from packing	1. The packing is too loose	Tighten the packing.
	2. Packing damaged or aged.	Change the packing.
PROBLEM	CAUSE	CLEAN UP METHOD
Leakage from bonnet gasket.	1. The bonnet bolt is not tightened enough.	Tighten the bolts.
	2. The gasket damaged.	Change the gasket.
Leakage from sealing face.	1. Foreign matter between the wedge and sealing faces.	Clean the sealing faces.
	2. Sealing face damaged.	Re-grind or replace the sealing face.
Valve cannot be totally closed.	1. Foreign matter deposited in valve body.	Clean the cavity.